

PLACE ON OUTER
SIDE OF CALIPER

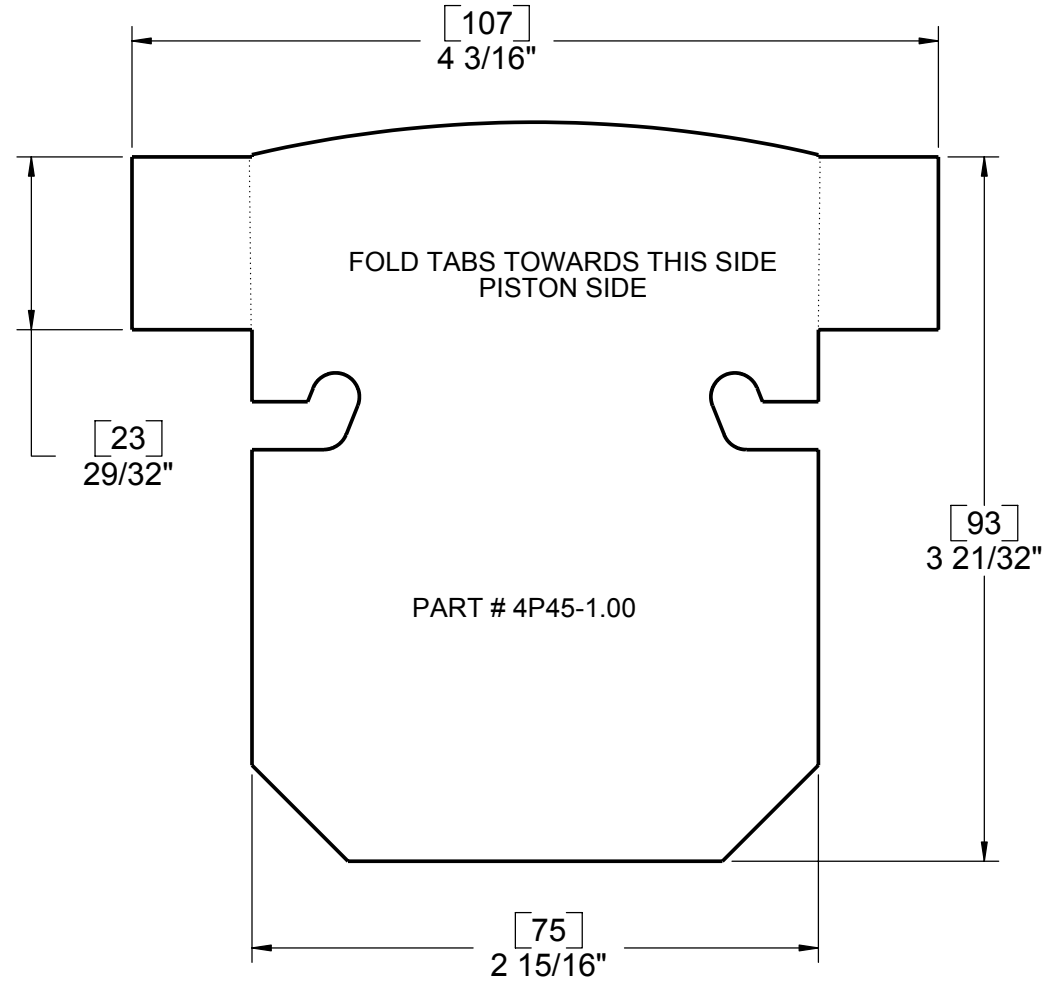

PLACE ON INNER
SIDE OF CALIPER

NOTES: KIT FP01000 INCLUDES TWO 4P45-.88 AND TWO 4P45-1.00 AND IS FOR USE ON ATE STYLE CALIPERS. SEE PAGE TWO FOR FITMENTS. LARGER WHEELS AND WHEEL SPACERS MAY BE REQUIRED FOR CLEARANCE. USE CUT-OUTS TO DETERMINE FITTING AND ORDER KIT FP01000.

DIRECTIONS: COPY OR PRINT ONTO CARD STOCK. MEASURE INDICATED DIMENSIONS AFTER PRINTING TO MAKE SURE SCALE IS ONE TO ONE. CUT ALONG DARK LINES - FOLD TABS ALONG DOTTED LINES TO SIMULATE HEATSINK HEIGHT. INSTALL BETWEEN BRAKE PAD AND CALIPER PISTON WITH PRINTED SIDE TOWARDS CALIPER PISTON. RE-INSTALL WHEEL AND CHECK CLEARANCE - MUST HAVE AT LEAST 3/32" CLEARANCE AT ALL POINTS.

MAKE SURE WHEEL BALANCING WEIGHTS WILL NOT HIT THE FSBC WHEN INSTALLED! REMOVE CUT-OUTS BEFORE DRIVING!